

# Assembly Length

HOSES  
ONE-PIECE B SERIES  
ONE-PIECE D SERIES  
ONE-PIECE F & P SERIES  
TWO-PIECE FERRULES (A & PFR SERIES)  
TWO-PIECE INSERTS (A SERIES)  
TWO-PIECE INTERLOCK FERRULES & INSERTS (X & Z SERIES)  
QUICK RELEASE  
ASSEMBLY EQUIPMENT

## How to Determine Correct Assembly Length



For most assemblies, the correct assembly length may be determined by direct measurement of the equipment or a drawing. Minimum bend radii as shown in the hose specification tables should be observed.

Assemblies are measured to the end of the seal.

To determine the length of hose needed in making assemblies with permanent or reusable couplings, subtract Dimension "C" (Cut off factor) for each coupling from the required overall assembly length. Dimension "C" may be found in the coupling specification tables.

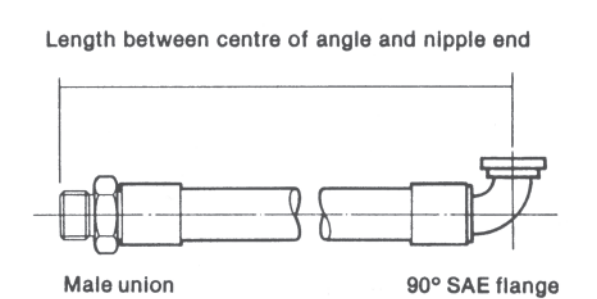
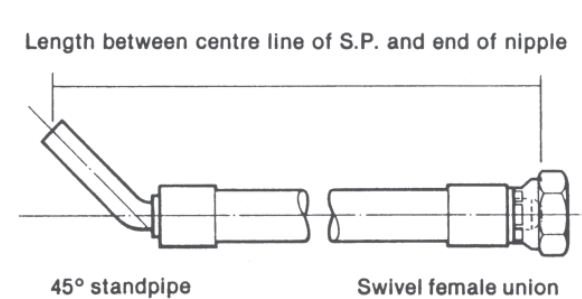
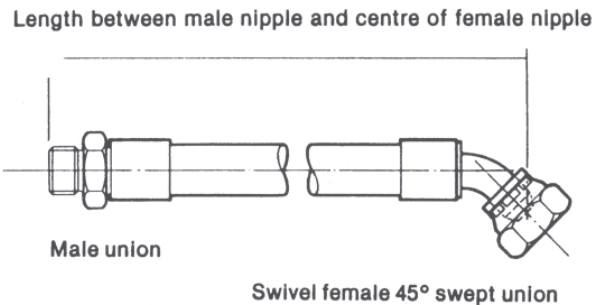
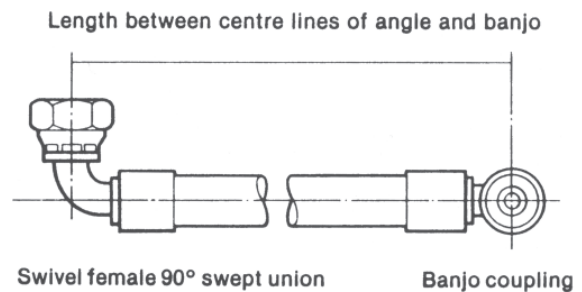
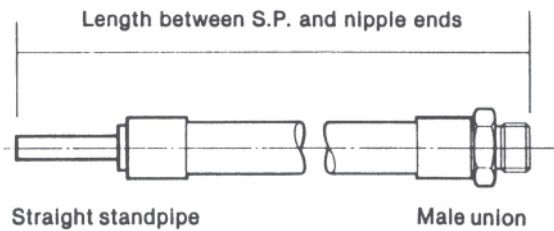
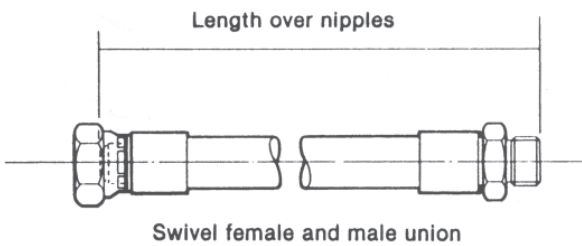

Remember that hydraulic hose under pressure will elongate up to 2% of its length or contract up to 4% depending on pressure, type and size. Sufficient allowance should be made to permit such changes in length.

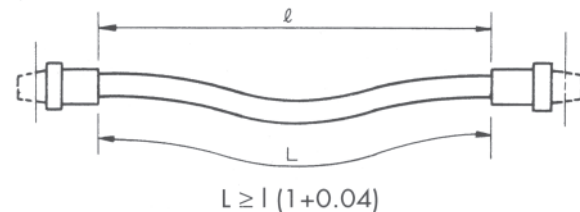

Because we continually examine ways to improve our products, we reserve the right to alter specifications or discontinue products without prior notice.

TECHNICAL INFORMATION

Occasionally an assembly will be required similar to the sketches to the right. The following equations are helpful in determining the correct length:

FOR 180° TURN APPLICATIONS

$$\#1 L = 2A + \pi R$$

$$\#2 L = 2A + \pi R + T$$

L = Overall length of the hydraulic hose assembly, in mm or inches.

A = Allowance for a minimum straight section of hydraulic hose at each end of the assembly, measure from the outer end of each coupling, in mm or inches. These two straight sections are necessary to prevent excessive stress concentrations directly back of the couplings. See table below.

R = Bending radius of the hose, in mm or inches. See hose specifications tables.

T = Amount of travel, in mm or inches.

Often right angle adapters provide a convenient means of avoiding a bend radius that is too small.

Hose ID	in.	1/4	5/16	3/8	1/2	5/8	3/4	1	1 1/4	1 1/2	2
mm		6.4	7.9	9.5	12.7	15.9	19	25	31.8	38.1	50.8
Min. "A"	in.	5	5	5	6	6	7	8	9	10	11
mm		127	127	127	152	152	178	203	229	254	279

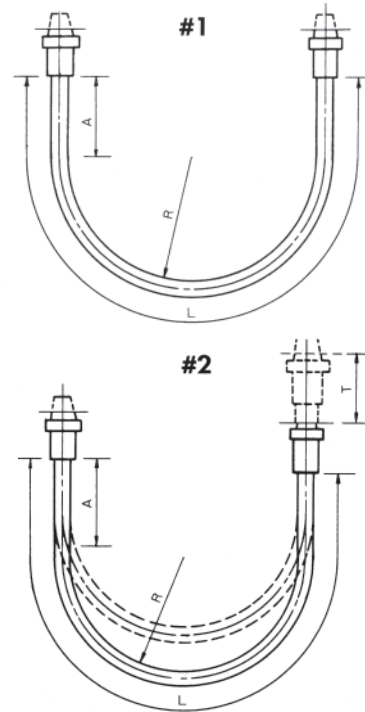

## Length Tolerance for Hydraulic Hose Assemblies and Specified Hose Lengths

### Length

- For lengths from 0 up to and including 12" (305 mm)
- For lengths > 12" (305 mm) < 18" (457 mm)
- For lengths > 18" (457 mm) < 36" (914 mm)
- For lengths > 36" (914 mm) < 48" (1219 mm)
- For lengths > 48" (1219 mm) < 72" (1830 mm)
- For lengths > 72" (1830 mm)

Elbow angle and angle of Orientation.

### Tolerance

- ± 1/8" ± 3 mm
- ± 3/16" ± 5 mm
- ± 1/4" ± 6 mm
- ± 3/8" ± 10 mm
- ± 1/2" ± 13 mm
- ± 1%

Tolerance ± 3

## Angle Couplings

A – To measure angle of offset of a hose assembly, point one end of coupling "A" (the nearest) to a vertical position downward. The angle can then be measured from the centerline of this vertical coupling "B" (the far coupling). See illustration at right.

Relationships can then be expressed from 0° to 360°. If angle is not given, elbows are positioned at 0°.

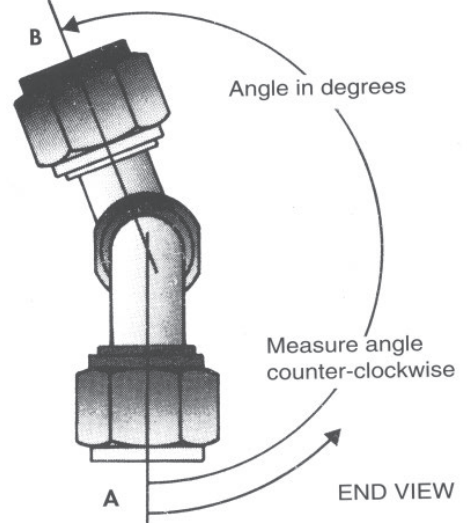

Because we continually examine ways to improve our products, we reserve the right to alter specifications or discontinue products without prior notice.